

Endura Standard Drawer Kit, 88mm M Height



Product Features

Upgrade your kitchen with Legacy Endura, a high-quality, cost-effective drawer system in stylish Silk White or Matte Grey. This sleek and modern solution complements any design, offering customizable configurations to maximize your space. Elevate your kitchen's functionality and aesthetic with the versatile and elegant Legacy Endura.

- Concealed full-extension soft-close slides
- 88mm drawer side height
- 6-way adjustment: Height (+/- 2mm), Lateral (+/- 1.5mm), Tilt (+0.5mm / -2.5mm)
- Tool free assembly and removal of drawer
- Dynamic load capacity: 40kg (88lbs)

Standard Drawer Kit (packaged as a complete set)

- One pair of Full Extension Soft-Close Slides
- One pair of Endura Drawer Sides
- One set of inner cover caps
- Two universal drawer front connectors (with expansion dowel)
- One set of rear bracket for drawer back panel

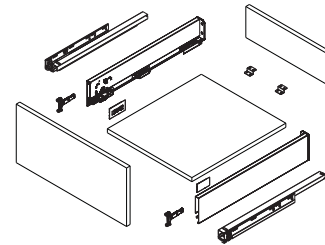

Standard Drawer Kit Ordering Guide

Length (mm)	Length (Inch)	Matte Grey	Silk White
270mm	11"	105-MS88T-GM270	105-MS88T-SW270
300mm	12"	105-MS88T-GM300	105-MS88T-SW300
350mm	14"	105-MS88T-GM350	105-MS88T-SW350
400mm	16"	105-MS88T-GM400	105-MS88T-SW400
450mm	18"	105-MS88T-GM450	105-MS88T-SW450
500mm	20"	105-MS88T-GM500	105-MS88T-SW500
550mm	22"	105-MS88T-GM550	105-MS88T-SW550
600mm	24"	105-MS88T-GM600	105-MS88T-SW600

Additional Parts (Optional)

Description	Part#
Press-In Front Fixing Clip 88mm M Height	105-HE11016X
Expansion Dowel Front Fixing Clip 88mm M Height	105-HE1101BX
Screw-On Front Fixing Clip 88mm M Height	105-HE11011X



Installation Dimensions Standard

Internal cabinet depth NL = Nominal Slide Length
 LT = Internal Cabinet Depth
 LT MIN=NL+3

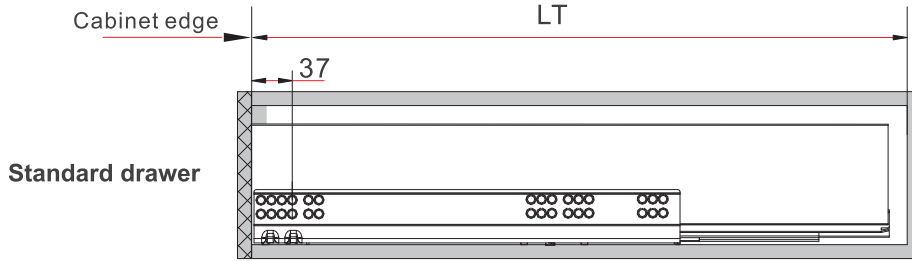

Space Requirements + Front Installation

Drilling Pattern

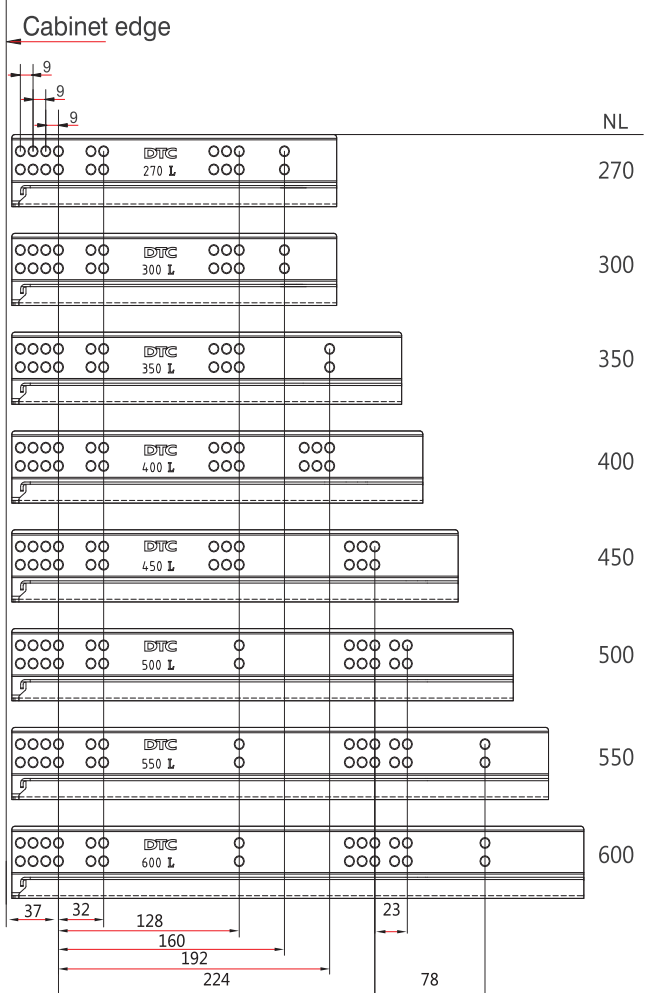
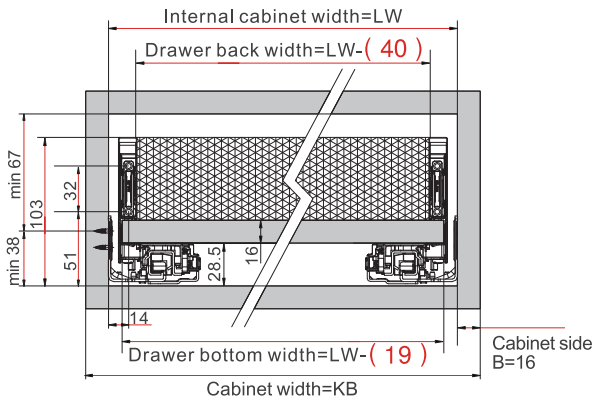

Back Installation

Drawer Front Drilling

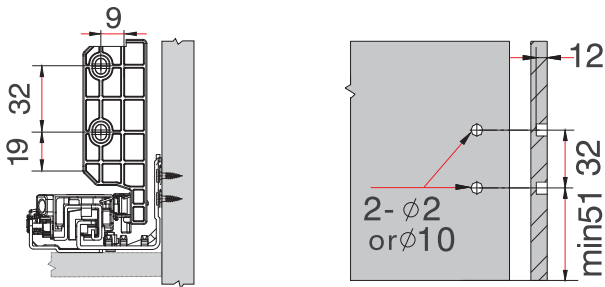



Back & Bottom Dimensions

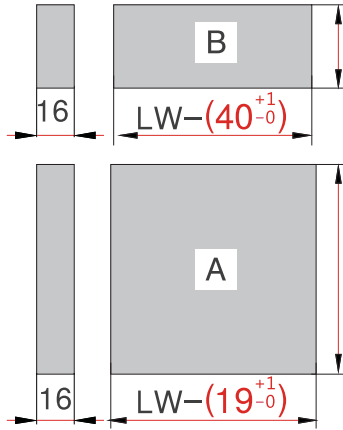

Back
63mm

Bottom
NL - (29 +0/-1) mm

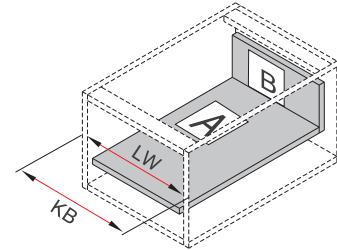

- KB Cabinet width
- LW Internal cabinet width
- NL Nominal length

Bottom & Back Assembly

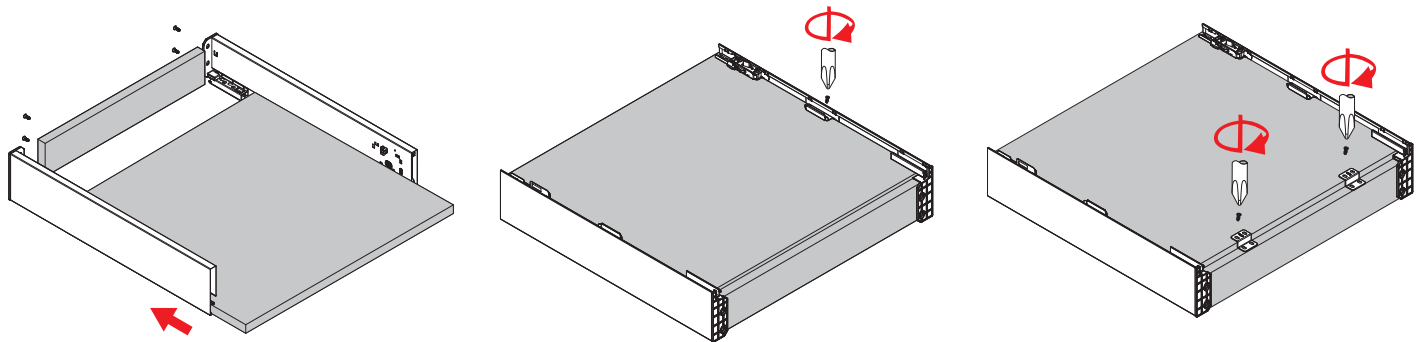

Drawer Front Assembly

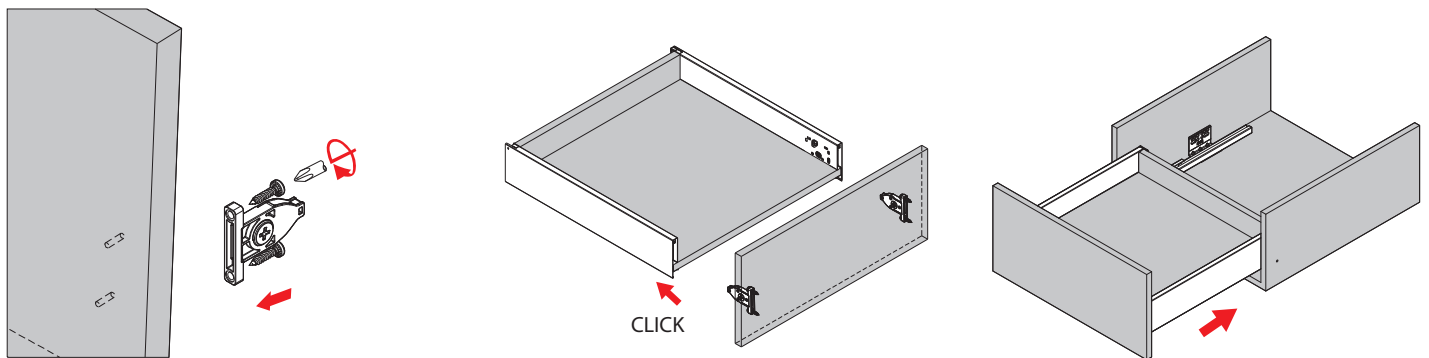

Fixing-Brackets Assembly

Drawer Front Assembly

Slide into the cabinet



Adjustments

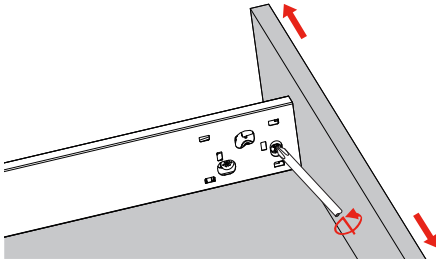

Lateral adjustment

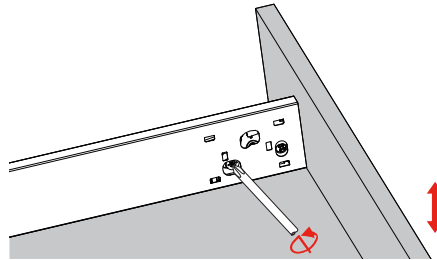

Height adjustment

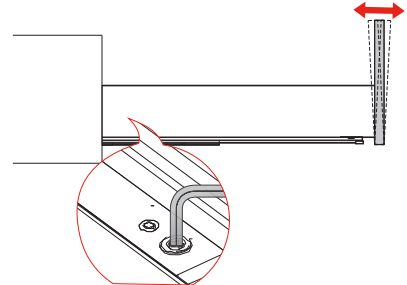

Tilt adjustment (by m3 Allen Key)

Removal

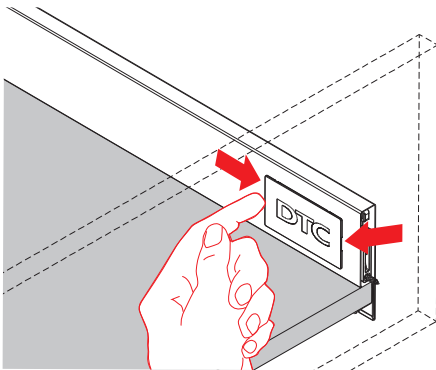

Remove the cover cap

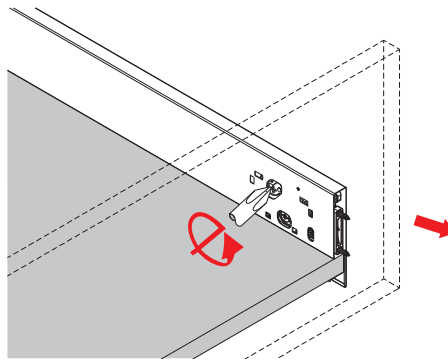

Turn screw driver to release the drawer front

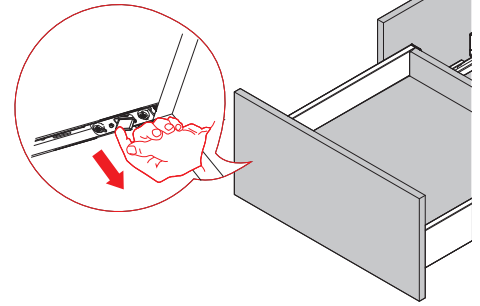

Press the locking device under the drawer box and pull out the drawer