

DEPENDENTLY ROTATING HARDWARE

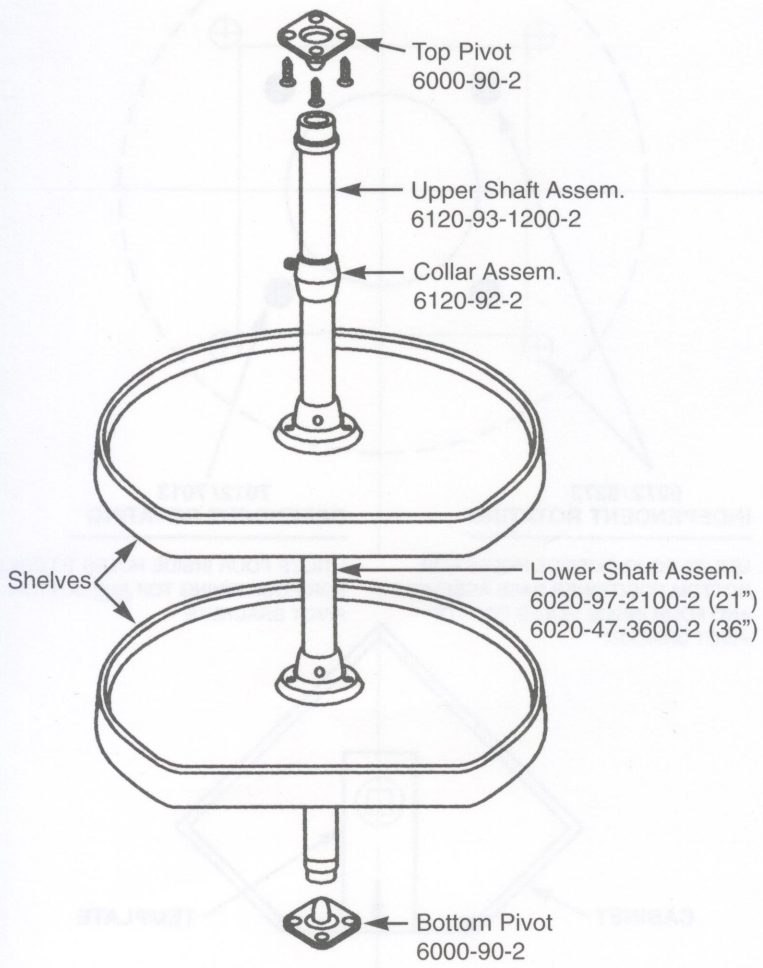

INDEPENDENTLY ROTATING HARDWARE

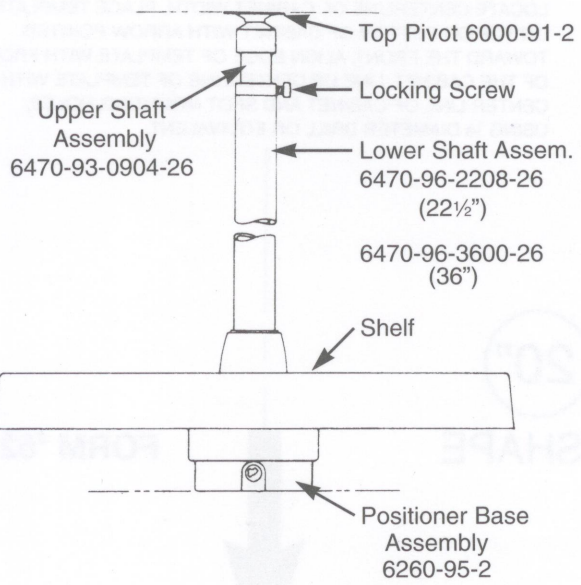

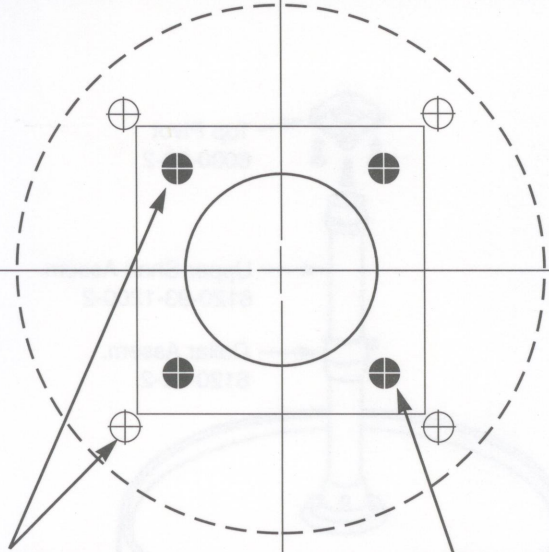

**6272/6273
 INDEPENDENT ROTATING**

UTILIZE FOUR OUTSIDE HOLES FOR
 BOTTOM POSITIONER BASE ASSEMBLY
 AND FOUR INSIDE HOLES FOR TOP
 PIVOT BRACKET

**7012/7013
 DEPENDENT ROTATING**

UTILIZE FOUR INSIDE HOLES TO DRILL
 FOR POSITIONING TOP AND BOTTOM
 PIVOT BRACKETS

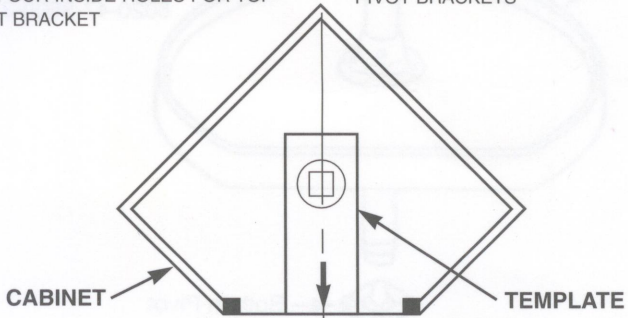

**CABINET
 CENTERLINE**

LOCATE ON CENTERLINE OF CABINET ALONG FRONT OPENING
 REV-A-SHELF 20" D-SHAPE POLYMER TRAY SET TEMPLATE

LOCATE CENTERLINE OF CABINET WIDTH. PLACE TEMPLATE
 ON TOP OR BOTTOM OF CABINET WITH ARROW POINTED
 TOWARD THE FRONT. ALIGN EDGE OF TEMPLATE WITH FRONT
 OF THE CABINET. LINE UP CENTERLINE OF TEMPLATE WITH
 CENTER LINE OF CABINET AND SPOT MOUNTING HOLES,
 USING 1/8" DIAMETER DRILL OR EQUIVALENT.

20"

D-SHAPE

FORM #6272-20



FRONT OF CABINET